

Up to 330 watt

WST-M6 Series

Top performance for all applications



PERFORMANCE
WARRANTY



COMPLIMENTARY
INSURANCE



Power to Perform



www.winaico.com.au

WST-M6 MONO FULL BLACK

325 W / 60 Cells

WSP-M6 MONO

325-330 W / 60 Cells



A reliable investment
Linear performance guarantee for 25 years



Advanced cell technology
For long term performance in all conditions



Safety for your roof
Rigorous testing and individual inspection of every panel



Extendable 15 year product guarantee
25 Year Product warranty on Registration for greater peace of mind

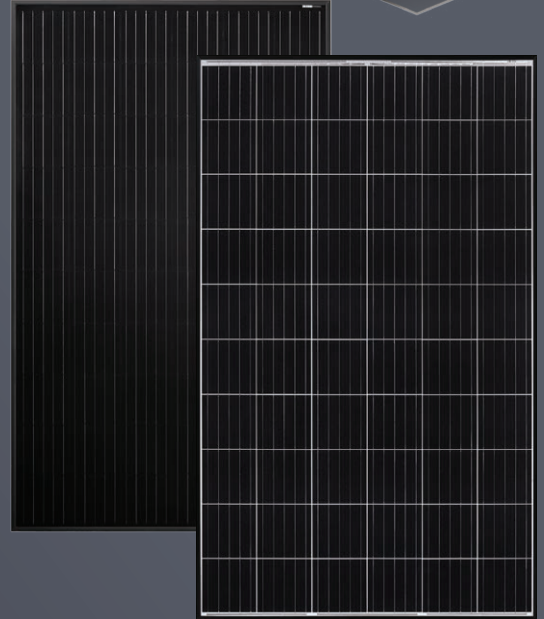

Greater Value

Premium quality from solar module specialists

A solar system is a long term investment, which should last for over 25-years. You need to be able to trust that the solar panels you install will perform for their whole life. With WINAICO you can rely on products from a manufacturer that specialises in premium quality solar.

Greater Experience

Thousands of satisfied system owners worldwide

Established in 2008 WINAICO is one of the world oldest solar manufacturers. Since inception we have focused on building close relationship with our customers. WINAICO stands for quality, reliability and customer engagement, values we apply every day in our business. Working closely with our customers builds trust and understanding, a feeling shared by thousands of satisfied customers worldwide. We have been awarded the EuPD Top PV Brand Award three years in a row.

Greater Protection

3 in 1 insurance for your complete system

Photovoltaic modules from WINAICO are characterised by outstanding quality, innovative design, durability and safety. In order to protect your system against property damage, operational interruption and reduced yields, we offer comprehensive all-round protection for your complete photovoltaic system when purchasing WINAICO modules.

Ask your installer and receive 2 years of free system protection.



Greater Quality Excellent Independent Ratings

WINAICO is one of the few manufacturers to be awarded the EUPD Research "Top Brand PV" seal. The award centres around customer satisfaction from the performance of their solar systems in the real world. The EUPD Seal reflects WINAICO's customer focus and the positive consensus on lifetime performance.



Greater Performance Leading Module Technology

WINAICO combines cutting edge components to build exceptional performance into every panel. Our advanced technology of light conducting ribbons maximises efficiency and minimises power loss to give you the best outcomes. We don't cut corners on quality, every piece of a WINAICO panel is designed for performance.



Greater Stability Protection Against the Extremes

With extreme weather becoming more frequent solar modules need to have the ability to withstand whatever nature throws at them, be it extreme heat, wind, hail or snow. WINAICO's unique frame and rigid design protects the panels and keeps them working hard for you!

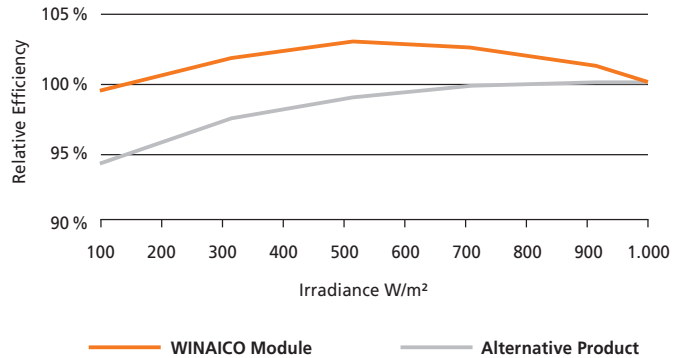

Greater Safety Tested to the Limits

WINAICO's modules are tested above and beyond international standards. Aiming to use lab conditions to simulate 25 years of service life, we push our modules to withstand conditions far above what they will likely experience on your roof. Be confident that your WINAICO panels will last the tests of time.



Greater Quality Control 100 % Inspection

We examine all cells and finished laminates for internal damage with a special electroluminescence testing device. In doing so, we can virtually eliminate all micro-cracks, hot spots, solder defects and other faults that cannot be seen with the naked eye. A type of "X-ray image" proves the 100% cell quality for each individual module.

Beyond Industry Standard Testing

Thermal Cycling (TC) Cycles between -40°C and +85°C	IEC Standard	200 Cycles
	WINAICO	3 times IEC standard
Damp Heat (DH) Constant +85°C and 85% relative humidity	IEC Standard	1,000 Hours
	WINAICO	3 times IEC standard
Mechanical Load (ML)	IEC Standard	5,400 Pa
	WINAICO	Follow IEC standard
Hail Impact	IEC Standard	25 mm ice ball at 83 km/h
	WINAICO	Follow IEC standard

We test beyond the Industry testing standards because at WINAICO we believe that our customers deserve complete peace of mind.

Enhanced Voluntary Quality Testing

Potential Induced Degradation (PID)	96 hours	1,000 V, 85°C, 85% relative humidity
Light and elevated Temperature Induced Degradation (LeTID)	Non-sensitive to LeTID	0.55A, 75°C, 162 hours, 2 cycles
Salt Mist (IEC 61701:2011)	Severity 6	40°C Humid storage, 90% relative humidity, 56 days
Ammonia (IEC 62716:2013)	480 hours	20 cycles between 8 hrs of heating up and 16 hrs of cooling test sections

Our modules are voluntarily submitted to testing laboratories to push them to the absolute limits, guaranteeing your safety and return on investment.

Dimensions

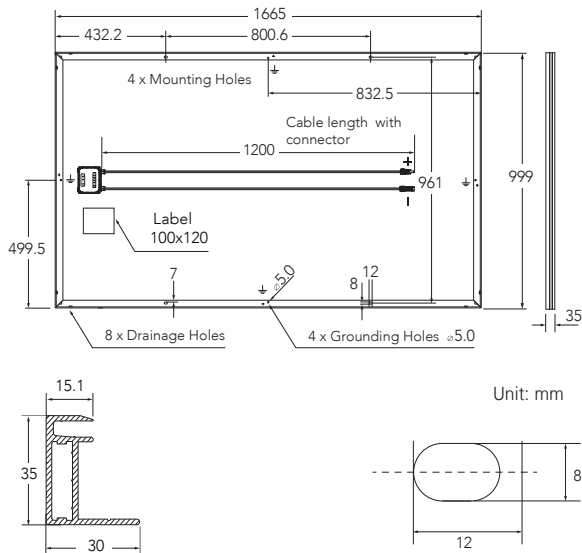

Frame Cross Section

Mounting Hole

Mechanical Data WINAICO WST-M6 FULL BLACK

Cell	Monocrystalline Silicon Cells, 158.75 mm x 158.75 mm
Quantity and wiring of cells	60 in series
Dimensions	1,665 mm x 999 mm x 35 mm (65.55 x 39.33 x 1.38 in)
Weight	18.6 kg (41.0 lbs)
Glass thickness	3.2 mm (0.13 in)
Frame	Black anodised aluminium
Junction box	IP 67
Connector type	MC4 (PV-KBT4/PV-KST4) IP68; QC4.10 IP68
Module fire performance	Type 4
Fire safety class	C

Mechanical Data WINAICO WST-M6

Cell	Monocrystalline Silicon Cells, 158.75 mm x 158.75 mm
Quantity and wiring of cells	60 in series
Dimensions	1,665 mm x 999 mm x 35 mm (65.55 x 39.33 x 1.38 in)
Weight	18.6 kg (41.0 lbs)
Glass thickness	3.2 mm (0.13 in)
Frame	Black anodised aluminium
Junction box	IP 67
Connector type	MC4 (PV-KBT4/PV-KST4) IP68; QC4.10 IP67
Module fire performance	Type 4
Fire safety class	C

Operating conditions	WINAICO WST-M6 FULL BLACK	WINAICO WST-M6
Operating temperature	-40°C to +85°C / -40°F to +185°F	-40°C to +85°C / -40°F to +185°F
Maximum system voltage IEC/UL	1,000V/1,000V	1,000V/1,000V
Maximum series fuse	20 A	20 A
Maximum design load (+)/(-)	3,600 Pa/2,400 Pa	3,600 Pa/2,400 Pa
Maximum test load (+)/(-)	5,400 Pa/3,600 Pa	5,400 Pa/3,600 Pa
Nominal Module Operating Temperature NMOT	43.85 ± 3°C	43.85 ± 3°C
Temperature coefficient of P _{MAX}	-0.38 %/°C	-0.38 %/°C
Temperature coefficient of V _{OC}	-0.29 %/°C	-0.29 %/°C
Temperature coefficient of I _{SC}	0.04 %/°C	0.04 %/°C
Certifications	IEC 61215-1:2016, IEC 61215-2:2016, IEC 61730-1:2016, IEC 61730-2:2016	

Electrical data (STC)	WST-325M6	WST-325M6	WST-330M6	
Nominal performance P _{MAX}	325	325	330	Wp
Voltage at maximum performance V _{MP}	33.92	33.92	34.27	V
Current at maximum performance I _{MP}	9.59	9.59	9.64	A
Open circuit voltage V _{OC}	40.70	40.70	40.85	V
Short circuit current I _{SC}	10.37	10.37	10.48	A
Module efficiency	19.54	19.54	19.84	%
Power tolerance	-0/+5		-0/+5	

Electrical data applies under standard test conditions (STC): solar radiation 1,000 W/m² with light spectrum AM 1.5, with cell temperature 25°C. Measurement tolerance of P_{MAX} at STC: ±3%. Accuracy of other electrical data: ±10%.

Electrical data (NMOT)	WST-325M6	WST-325M6	WST-330M6	
Nominal performance P _{MAX}	237	237	240	Wp
Voltage at maximum performance V _{MP}	31.17	31.17	31.48	V
Current at maximum performance I _{MP}	7.60	7.60	7.64	A
Open circuit voltage V _{OC}	38.34	38.34	38.48	V
Short circuit current I _{SC}	8.20	8.20	8.28	A

Electrical data applies under Nominal Module Operating Temperature (NMOT), irradiance of 800 W/m², spectrum AM 1.5, ambient temperature 20°C, wind speed 1 m/s.



WINAICO Australia Pty Ltd

Tel + 61 2 8091 2771

australia@winaico.com

<https://www.winaico.com.au/>

3/393 George Street, Sydney NSW 2000, Australia



Power to Perform